

PERGOLA (SHADE STRUCTURE)

Pergolas must remain 50% open at the roof and cannot have any openings less than 4" on the roof surface. Detached pergolas, not over a deck, less than two hundred (200) square feet and accessory to one- or two-family dwellings, are exempt from permitting.

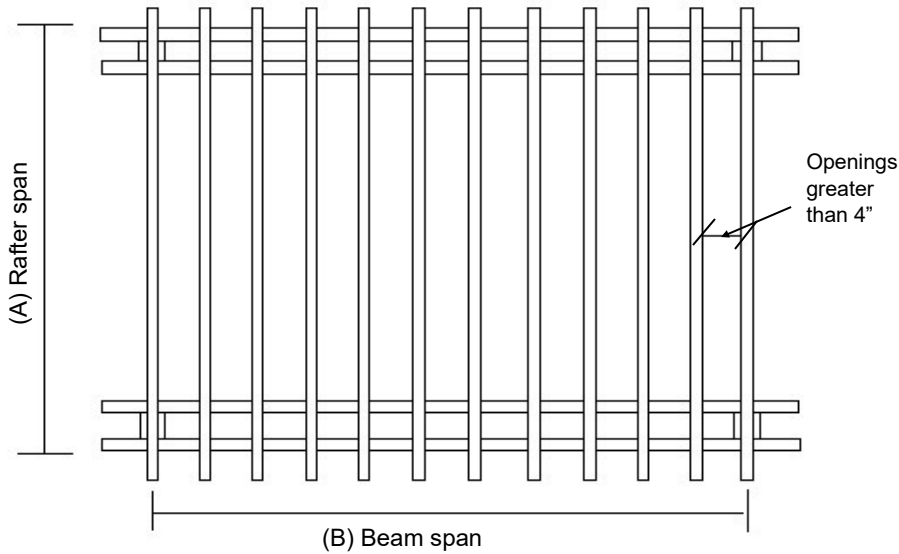

EXAMPLE FRAMING PLAN

PLOT PLAN

A site/plot plan review is required for all pergolas, permitted or not. Contact the zoning department having jurisdiction for additional information.

El Paso County	719-520-6300	Colorado Springs	719-385-5982
Fountain	719-382-8521	Manitou Springs	719-685-4398
Monument	719-481-2954	Palmer Lake	719-481-2953
Green Mountain Falls	719-684-9414	Woodland Park (City limits)	719-687-5202

- **Complete street address.**
- **Legal description of property.**
- **Property lines and dimensions.** Include side, front and rear yards.
- **All site improvements,** including existing and proposed new construction (deck, patio enclosure, garage, etc.)

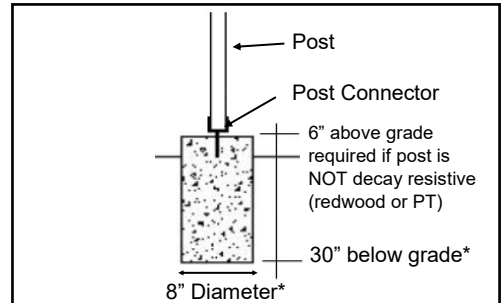

*If all piers loads are <750 pounds, 10" diameter by 12" deep piers are allowed, or support directly on existing 4" slab.

PIER DETAIL

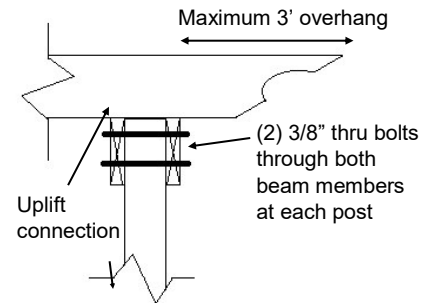

BEAM / RAFTER CONNECTION

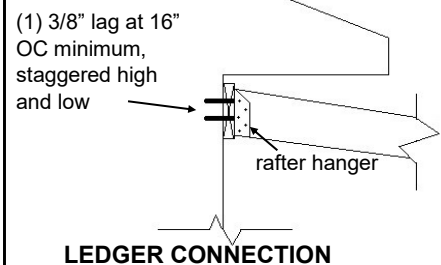

LEDGER CONNECTION

Tables are based on REDWOOD #2 or better lumber

RAFTER SPAN (feet)	(A) MINIMUM JOIST SIZE			(B) MINIMUM BEAM SIZE					
	12" OC	16" OC	24" OC	with post spacing at:					
				5 feet	6 feet	7 feet	8 feet	9 feet	10 feet
6	2 x 4	2 x 4	2 x 4	2 - 2 x 4	2 - 2 x 4	2 - 2 x 4	2 - 2 x 4	2 - 2 x 4	2 - 2 x 6
7	2 x 4	2 x 4	2 x 4	2 - 2 x 4	2 - 2 x 4	2 - 2 x 4	2 - 2 x 4	2 - 2 x 6	2 - 2 x 6
8	2 x 4	2 x 4	2 x 4	2 - 2 x 4	2 - 2 x 4	2 - 2 x 4	2 - 2 x 4	2 - 2 x 6	2 - 2 x 6
9	2 x 4	2 x 4	2 x 4	2 - 2 x 4	2 - 2 x 4	2 - 2 x 4	2 - 2 x 4	2 - 2 x 6	2 - 2 x 6
10	2 x 4	2 x 4	2 x 4	2 - 2 x 4	2 - 2 x 4	2 - 2 x 4	2 - 2 x 6	2 - 2 x 6	2 - 2 x 6
11	2 x 4	2 x 4	2 x 6	2 - 2 x 4	2 - 2 x 4	2 - 2 x 4	2 - 2 x 6	2 - 2 x 6	2 - 2 x 6
12	2 x 4	2 x 6	2 x 6	2 - 2 x 4	2 - 2 x 4	2 - 2 x 4	2 - 2 x 6	2 - 2 x 6	2 - 2 x 6
13	2 x 6	2 x 6	2 x 6	2 - 2 x 4	2 - 2 x 4	2 - 2 x 4	2 - 2 x 6	2 - 2 x 6	2 - 2 x 6
14	2 x 6	2 x 6	2 x 6	2 - 2 x 4	2 - 2 x 4	2 - 2 x 4	2 - 2 x 6	2 - 2 x 6	2 - 2 x 6
15	2 x 6	2 x 6	2 x 6	2 - 2 x 4	2 - 2 x 4	2 - 2 x 6	2 - 2 x 6	2 - 2 x 6	2 - 2 x 8
16	2 x 6	2 x 6	2 x 8	2 - 2 x 4	2 - 2 x 4	2 - 2 x 6	2 - 2 x 6	2 - 2 x 6	2 - 2 x 8